



How does nicotinic acid modify the lipid profile?

M. John Chapman

Dyslipidemia and Atherosclerosis Research Unit U 551 INSERM Hôpital de la Pitié 83, boulevard de l'Hôpital, 75651 Paris Cedex 13, France

KEYWORDS

HDL-cholesterol;
Atherosclerosis;
Dyslipidaemia;
Nicotinic acid;
Niacin;
Lipolysis

An atherogenic dyslipidaemic phenotype, characterized by low HDL-cholesterol levels, hypertriglyceridaemia and small, dense LDL, is commonly observed in patients with type 2 diabetes, the metabolic syndrome, or pre-existing cardiovascular disease and is inadequately addressed by current guidelines for the management of cardiovascular disease. Moreover, low HDL-cholesterol, in particular, is common among patients treated for dyslipidaemia and is little affected by statin treatment. Incomplete suppression of lipolysis by insulin in the fed state in insulin-resistant subjects leads to increased lipolysis in adipose tissue with elevated circulating free fatty acids (FFA). This metabolic abnormality leads directly to the development of the atherogenic dyslipidaemic phenotype. Nicotinic acid increases levels of HDL-cholesterol, probably largely through suppression of lipolysis in adipocytes secondary to activation of specific, G-protein-coupled nicotinic acid (HM74A) receptors. The reduction in FFA flux after nicotinic acid treatment also results in reduced levels of circulating triglycerides, mainly in the form of VLDL, and increased size and buoyancy of LDL. Treatment with nicotinic acid equally increases the size of HDL particles, which may promote increased reverse cholesterol transport from macrophages in the atherosclerotic plaque via the ABCG1 cholesterol transporter. The effects of nicotinic acid on the lipid profile are thus potentially anti-atherogenic and may address a major source of cardiovascular risk in insulin-resistant populations, such as those with the metabolic syndrome, type 2 diabetes and/or cardiovascular disease.

Introduction: correction of dyslipidaemia: current practice

Guidelines and risk scoring

Correction of dyslipidaemia is central to the management of cardiovascular risk.^{1,2} The first step in designing interventions for patients at elevated cardiovascular risk is often to determine their overall cardiovascular risk, and the principal guidelines for the management of cardiovascular risk in current use set about this task in different ways. Joint guidelines from European expert societies¹ use the Systematic Coronary Risk Evaluation (SCORE) system, which estimates the 10-year risk of fatal cardiovascular disease, on the basis of gender, age, total cholesterol level, systolic blood pressure, and

smoking status.³ Framingham scoring is used in guidelines from the National Cholesterol Education Program/Adult Treatment Panel III,² which are most relevant to clinical practice in the USA, but are highly influential elsewhere. The online Framingham risk calculator provided by the US government⁴ estimates the 10-year risk of myocardial infarction, on the basis of same parameters, with the addition of HDL-cholesterol. Most guidelines themselves identify HDL-cholesterol <40 mg/dL (1.03 mmol/L) in men or <50 mg/dL (50 mmol/L) in women as 'low', but to date fall short of recommending treatment goals for this parameter.

Limitations of guideline recommendations

The omission of HDL-cholesterol from the European system might lead to the underestimation of cardiovascular risk in important subgroups of patients. HDL-cholesterol has

Corresponding author. Tel: +33 1 42 17 78 78; fax: +33 1 42 17 78 78.
E-mail address: chapman@chups.jussieu.fr

been shown to be an important determinant of overall cardiovascular risk in large observational cohort studies, including the Framingham study among others.⁵⁻⁷ Moreover, a distinct dyslipidaemic phenotype has been identified that is strongly associated with insulin-resistant states such as abdominal obesity, the metabolic syndrome, or type 2 diabetes: these patients often present with normal or only mildly elevated LDL-cholesterol or total cholesterol, and have low HDL-cholesterol, hypertriglyceridaemia and a shift in the LDL subclass distribution towards small, dense particles.⁸⁻¹¹

This phenotype is believed to favour plaque cholesterol accumulation, as shown schematically in *Figure 1*.¹² Indeed, the lipid core of a mature complex plaque frequently contains a substantial amount of crystalline cholesterol,¹³ with the overall atheroma burden determined to a major degree by the balance of influx and efflux of cholesterol. In general, cholesterol is delivered to the plaque by ApoB-containing lipoproteins, while reverse cholesterol transport by HDL (ApoAI-containing lipoproteins) removes a proportion of excess cholesterol and delivers it to the liver via the plasma compartment for catabolism or recycles it back to ApoB-containing lipoproteins via cholesteryl ester transfer protein (CETP). Where cholesterol influx outstrips efflux, as in a patient with elevated LDL-cholesterol or a low level of HDL-cholesterol, the plaque grows, attracts more inflammatory cells, and inflammatory remodelling of the fibrous cap may render it thin and fragile.¹⁴ Overall, the risk of a morbid cardiovascular event is increased sharply. Reducing levels of LDL-cholesterol and/or increasing levels of HDL-cholesterol can potentially stabilize or even reverse this situation, leading to a more stable plaque and reduced risk of cardiovascular events.¹⁵

Unmet clinical need

Correction of the components of the atherogenic dyslipidaemic phenotype associated with insulin resistance is, therefore, likely to be therapeutically beneficial, in addition to the guideline-driven correction of

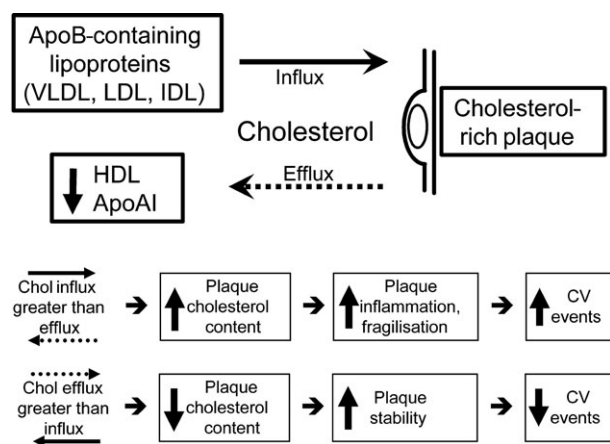

Figure 1 Schematic representation of the dynamics of atherosclerosis and increased cardiovascular (CV) risk in terms of cholesterol transport.¹²

LDL-cholesterol and blood pressure. Indeed, randomized outcome trials provide strong support to the principle of correcting low HDL-cholesterol (reviewed by Brown).¹⁶ The high prevalence of low HDL-cholesterol (33% in men and 40% in women)¹⁷ in patients under treatment for dyslipidaemia in Europe suggests that this lipid disorder represents an unmet clinical need. Treatment with nicotinic acid (niacin in some countries) or a fibrate increases HDL-cholesterol. Nicotinic acid is more effective in this regard, and is the most effective agent currently available for increasing levels of HDL-cholesterol.² The purpose of this review is to consider in detail the biochemical pharmacology of nicotinic acid.

Actions of nicotinic acid on the lipid profile

Biochemical pharmacology of nicotinic acid

Nicotinic acid is a member of the B-vitamin family and is sometimes referred to as vitamin B₃. Conversion *in vivo* to nicotine adenine dinucleotide (NAD⁺⁺, or NADH in its reduced form) is an important part of the biological action of nicotinic acid overall. This molecule serves as a hydrogen acceptor/donor involved in countless biochemical reactions, especially those involving energy transduction, and may also have a role in cellular signaling and modification of proteins.¹⁸ These actions are unlikely to be involved in the modulation of lipids by nicotinic acid, however, as much higher serum concentrations of nicotinic acid are required to increase levels of HDL-cholesterol than are usually available in the diet.

Recent research has identified a likely mechanism for the effects of nicotinic acid on the lipid profile, more than 50 years after these effects were first demonstrated.¹⁹ Two groups independently identified, HM74, a previously 'orphan' G-protein-coupled receptor expressed at high levels in human adipocytes, as a nicotinic acid receptor.^{20,21} One of these studies also identified HM74A, a second nicotinic acid receptor with higher affinity.²¹ Importantly, administration of nicotinic acid to mice lacking the murine version of HM74 (PUMA-G) does not induce the usual changes in lipid metabolism expected from nicotinic acid treatment,²⁰ suggesting that the HM74/HM74A receptor is physiologically important in mediating the effects of nicotinic acid on the lipid profile.

The cellular events following the binding of nicotinic acid to HM74A are as follows.²² Recruitment of an inhibitor G-protein reduces the activity of adenylate cyclase, thus reducing cellular levels of cyclic adenosine monophosphate (cAMP). The reduction in cAMP levels reduces the activity of protein kinase A which, in turn, reduces the activity of hormone-sensitive lipase. The net result of these actions on the adipocyte is a reduction in the rate of lipolysis and a reduction in free fatty acid (FFA) output from adipocytes.

This mechanism is consistent with the effects of nicotinic acid on the functions of adipocytes in humans. *Figure 2* shows the results of a study in which an immediate-release formulation of nicotinic acid was administered to patients with diabetes.²³ Another group

of type 2 diabetes patients not receiving nicotinic acid served as controls. There was a transient but clear reduction in circulating FFA levels after administration of nicotinic acid. This phenomenon and the subsequent rebound in FFA levels, after the effect of the drug had worn off, are typical of the effects of immediate-release nicotinic acid in diabetic or non-diabetic humans.

Correction of atherogenic dyslipidaemia by nicotinic acid

Aetiology of dyslipidaemia associated with insulin resistance

Insulin resistance is central to the development of low HDL-cholesterol, hypertriglyceridaemia and small,

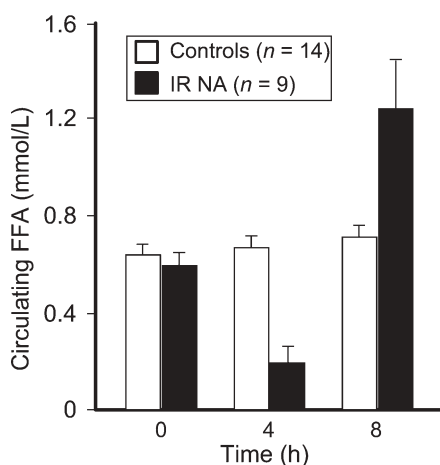

Figure 2 Mean (SE) serum FFA levels after administration of immediate-release nicotinic acid (IR NA) to subjects with type 2 diabetes. After a 16-h fast, nicotinic acid was administered to nine type 2 diabetic subjects at a total dose of 1100 mg in divided doses over a 4-h period (0–4 h in the figure). A further 14 type 2 diabetic subjects not given nicotinic acid served as controls. Subjects continued to fast throughout the experiment. Drawn from data presented by Boden *et al.*²³

dense LDL (Figure 3).^{11,24} Normally, in the fed state, insulin virtually completely suppresses FFA production by adipocytes, also through a cAMP-dependent mechanism as described above. Lipolysis persists in the setting of insulin resistance, however, despite the presence of hyperinsulinaemia, and the liver is exposed to chronically high levels of FFA. This is essentially the basis of the atherogenic dyslipidaemic phenotype.

Hypertriglyceridaemia: the excess FFA in the liver are esterified and converted to triglycerides with packaging into triglyceride-rich VLDL. High rates of hepatic VLDL production result in progressive accumulation of these particles in the circulation with ensuing hypertriglyceridaemia.

Altered HDL and LDL phenotypes: CETP mediates heterotransfer of triglycerides from VLDL to HDL in exchange for cholesteryl ester moving in the opposite direction. Abnormally high VLDL triglyceride concentrations in insulin resistance increase the rate of transfer, leading to the formation of triglyceride-rich HDL. Lipolysis of the excess triglycerides reduces the size of HDL particles and increases their density. Small, dense HDLs are catabolized in the kidney and excreted more rapidly than larger HDLs, resulting in low circulating HDL-cholesterol levels. In a similar manner, CETP acts to transfer TG from VLDL to LDL; upon hydrolysis by hepatic lipase, small dense LDL are produced (Figure 3).

Effects of nicotinic acid on the lipid profile

The effects of nicotinic acid on the lipid profile are summarized in Figure 4. Clearly, reduced lipolysis in adipocytes in nicotinic acid-treated patients, as described above, would result in reduced hypertriglyceridaemia, together with higher levels of HDL-cholesterol and larger LDL. Increasing the proportion of HDL particles within the larger, more buoyant subclasses would also increase the potential for reverse cholesterol transport from peripheral cells, including that from macrophages via ABCG1 within an evolving atherosclerotic plaque. Potentially beneficial effects of nicotinic acid on

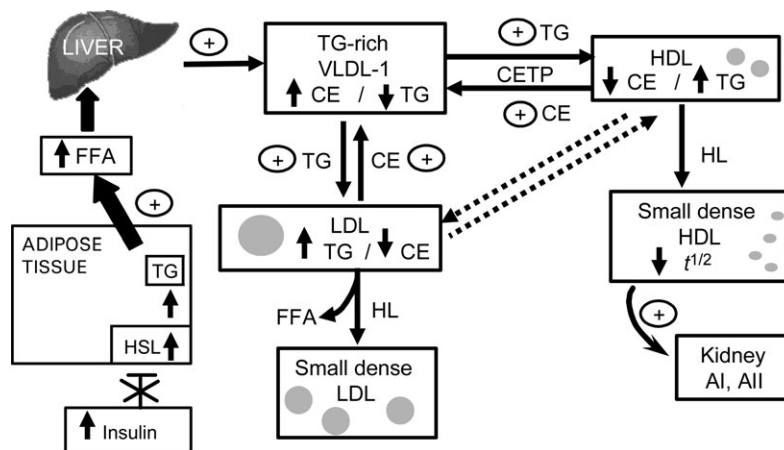

Figure 3 Metabolic basis of the atherogenic dyslipidaemic phenotype associated with insulin resistance. Adapted from Chapman MJ. Fibrates in 2003: therapeutic action in atherogenic dyslipidaemia and future perspectives. *Atherosclerosis*; 171:1–13, copyright (2003) with permission from Elsevier.

lipoprotein subclasses have been observed in humans. Two of these studies evaluated Niaspan[®], a once-daily prolonged release formulation of nicotinic acid that is as effective as the immediate-release formulation but better tolerated.²⁵

A 16-week, randomized study compared the effects of a combination of Niaspan[®] with lovastatin, at doses of 2000 and 40 mg, respectively, with those of monotherapy with atorvastatin or simvastatin in 315 patients with hypercholesterolaemia (Table 1).²⁶ Effects on overall levels of lipoproteins were as expected with these treatments, with larger increases in HDL-cholesterol with the combination as compared to that with statin monotherapies ($P < 0.001$), and with broadly similar effects on LDL-cholesterol (although atorvastatin was more effective than simvastatin on this parameter).

Lipoprotein subclass distributions were determined in this study using polyacrylamide gel electrophoresis. Different commercial methodologies for evaluating lipoprotein subclass distributions give rise to different

classifications, which complicates comparisons between studies. In this case, HDL particles were divided into five subclasses (3c, 3b, 3a, 2a, and 2b, in increasing order of peak particle diameter) and LDLs were subdivided into seven subclasses (IVb, IVa, IIIb, IIIa, IIb, IIa, and I, in increasing order of peak particle diameter).²⁷ It is believed that a reduction in LDL size increases their atherogenicity.^{8,9}

The combination treatment increased the proportion of HDL particles in the largest measured HDL subclass (HDL2b) by 42%, an effect significantly greater ($P < 0.001$) than the corresponding changes in patients randomized to treatment with either statin given as monotherapy. In addition, treatment with Niaspan[®] plus lovastatin, compared with statin monotherapy, was associated with a greater increase in the peak particle diameter of LDL ($P < 0.001$ vs. atorvastatin or simvastatin), a reduction in the proportion of subjects with peak LDL particle diameter $< 257 \text{ \AA}$ ($P < 0.001$ vs. atorvastatin or simvastatin) and a reduction in the proportion

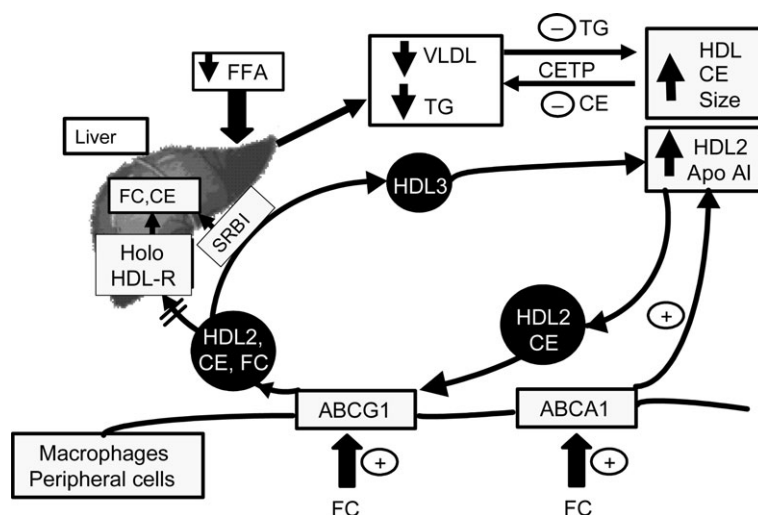

Figure 4 Effects of nicotinic acid on the atherogenic dyslipidaemic phenotype associated with insulin resistance.

Table 1 Effects of Niaspan[®] combined with a statin on lipoprotein subclasses²⁶

	Per cent change from baseline		
	Niaspan [®] 2000 mg + lovastatin 40 mg	Atorvastatin 40 mg	Simvastatin 40 mg
HDL			
Mean HDL-cholesterol	+33 ^{a,b}	+6	+7
Proportion of HDL2b subclass	+41.8 ^{a,b}	+16.7	+5.2
LDL			
Mean LDL-cholesterol	-42 ^c	-49	-39
LDL peak particle diameter	+9.9 ^{c,d}	+2.6	+2.1
Proportion with LDL IIIa/IIIb	-13.6	-4.5	+4.3

^a $P < 0.001$ vs. atorvastatin

^b $P < 0.001$ vs. simvastatin.

^c $P < 0.01$ vs. atorvastatin.

^d $P < 0.01$ vs. simvastatin.

Lipoprotein subclasses were measured using polyacrylamide gel electrophoresis; see text for explanations of HDL2b and LDLIIIa/IIIb subclasses.

of LDL in the atherogenic LDL IIIa and IIIb categories ($P < 0.001$ vs. simvastatin).

Nuclear magnetic resonance (NMR) analysis provides a different classification, where H1 is the smallest and densest HDL, and H5 is the largest (H5 on NMR corresponds roughly to HDL2b on gel electrophoresis).²⁶ Similarly, L1 is the smallest subclass of LDL on NMR analysis and L3 the largest.²⁶ The effects of 12 weeks of Niaspan[®] monotherapy (daily doses of 1000 or 2000 mg) on NMR lipoprotein subclass distributions were evaluated in 60 patients with primary hypercholesterolaemia enrolled in a double-blind, randomized, placebo-controlled trial.²⁸ Changes from baseline in H5 (large, buoyant) HDL were +70% and +89% for the Niaspan[®] 1000 mg and 2000 mg, respectively, with a decrease of 5% on placebo ($P < 0.001$). A trend towards larger particles in the larger L3 subclass profile, with a greater proportion in the larger L3 class was also observed, although this did not achieve statistical significance in this small study.

Discussion

We have numerous pharmacological agents available for clinical use in patients with dyslipidaemia. The results of many well-designed outcome studies have placed control of ApoB-containing lipoproteins with statins firmly at the centre of current lipid management strategies. We should remember, however, that dyslipidaemia is a highly heterogeneous condition, driven by multiple pathologies and with multiple phenotypes. Sedentary habits and poor diets are fuelling the twin global pandemics of obesity (particularly abdominal obesity) and diabetes.²⁹ These trends, driven by insulin resistance, are likely to increase the prevalence of the atherogenic dyslipidaemic phenotype in the near future.

Statins reduce cardiovascular event rates in insulin-resistant populations, as shown in the Collaborative Atorvastatin Diabetes Study (CARDS), which demonstrated a 37% risk reduction vs. placebo for major cardiovascular events in patients with type 2 diabetes.³⁰ This is unsurprising, as randomized studies show that statins appear to reduce cardiovascular event rates in populations with increased cardiovascular risk of any aetiology.³¹ However, even intensive intervention with a statin has yet to deliver cardiovascular risk reductions in excess of 40%.³¹ Statins modestly reduce levels of triglycerides but usually do not exert clinically relevant effects on levels of HDL-cholesterol.³² The Pan-European Survey of HDL-cholesterol recently measured lipid levels in 8545 patients under specialist care for dyslipidaemia in 11 countries in Europe.¹⁷ Patients in this survey were stratified according to receipt or not of lipid-modifying treatment, which almost always involved a statin and only rarely involved nicotinic acid or a fibrate. It is interesting to note that the prevalence of low HDL-cholesterol (NCEP/ATPIII criteria) was almost the same in treated or untreated men (32.5 vs. 34.4%, respectively) or women (39.9 vs. 38.5%, respectively). A similar pattern was observed for the prevalence of very

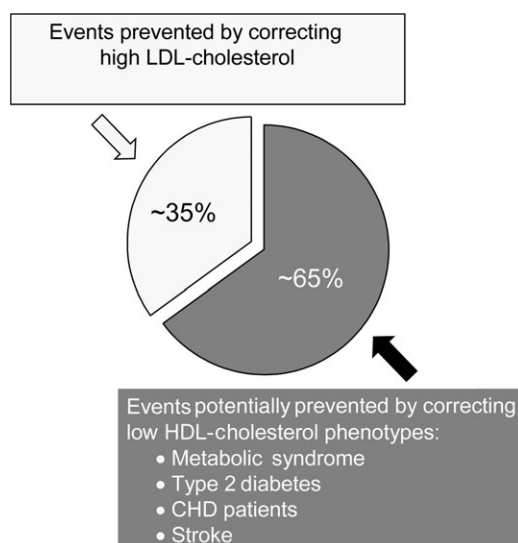

Figure 5 Clinical importance of addressing low HDL-cholesterol phenotypes in addition to hyperlipidaemia.

low HDL-cholesterol (<0.9 mmol/L [35 mg/dL], both genders combined), which was 14.4% in treated patients and 13.1% in untreated patients.

This large and well-conducted survey provides clear evidence that statin-based treatment exerts little impact on low HDL-cholesterol. The high prevalence of low HDL-cholesterol, and its status as an independent cardiovascular risk factor have led to recommendations from expert consensus groups on both sides of the Atlantic to strengthen recommendations in cardiovascular management guidelines for intervention to correct low HDL-cholesterol levels.^{33,34}

Adding a second agent such as nicotinic acid to a statin provides an alternative strategy to statin monotherapy that may help to make inroads into the roughly 65% of original cardiovascular risk remaining after intervention with a statin (Figure 5). Moreover, this approach is likely to address the actual dyslipidaemic phenotype found in insulin-resistant populations, including patients with the metabolic syndrome, type 2 diabetes, or established cardiovascular disease.

Conclusions

Treatment with nicotinic acid reduces the rate of lipolysis in adipocytes, thereby leading to decreased flux of FFA to the liver with reduced VLDL production. Overall levels of HDL-cholesterol are increased due to retention of cholesterol in HDL particles, via a CETP-mediated mechanism. In addition, the broad spectrum lipid-modifying action of nicotinic acid attenuates other features of the atherogenic dyslipidaemic phenotype (hypertriglyceridaemia and dense LDL profile). Adding nicotinic acid to a statin addresses an important source of cardiovascular risk in many patients that is inadequately addressed by treatment with statin monotherapy.

Conflict of interest: Dyslipidaemia and Atherosclerosis Research Unit has received research grants from AstraZeneca, Fournier, Sanofi, Merck, MSD and Pfizer, and M.J.C. has received honoraria for participation in educational symposia organized by these companies.

References

1. Third Joint Task Force of European and other Societies on Cardiovascular Disease Prevention in Clinical Practice (constituted by representatives of eight societies and by invited experts). European guidelines on cardiovascular disease prevention in clinical practice. *Eur J Cardiovasc Prev Rehabil* 2003;10:S1–S10.
2. National Cholesterol Education Program. Third report of the expert panel on detection, evaluation, and treatment of high blood cholesterol in adults (adult treatment panel III). National Institutes of Health/National Heart Lung and Blood Institute. www.nhlbi.nih.gov/guidelines/cholesterol (February 2006).
3. HeartScore Programme: the interactive tool for predicting and managing the risk of heart attack and stroke in Europe. http://www.escardio.org/knowledge/decision_tools/heartscore (February 2006).
4. Risk assessment tool for estimating your 10-year risk of having a heart attack. <http://hin.nhlbi.nih.gov/atp/iii/calculator.asp> (February 2006).
5. Wilson PW, Abbott RD, Castelli WP. High density lipoprotein cholesterol and mortality. The Framingham Heart Study. *Arteriosclerosis* 1988;8:737–741.
6. Goldbourt U, Yaari S, Medalie JH. Isolated low HDL cholesterol as a risk factor for coronary heart disease mortality. A 21-year follow-up of 8000 men. *Arterioscler Thromb Vasc Biol* 1997;17:107–113.
7. Tanne D, Yaari S, Goldbourt U. High-density lipoprotein cholesterol and risk of ischaemic stroke mortality. A 21-year follow-up of 8586 men from the Israeli Ischaemic Heart Disease Study. *Stroke* 1997;28: 83–87.
8. Watson KE, Horowitz BN, Matson G. Lipid abnormalities in insulin resistant states. *Rev Cardiovasc Med* 2003;4:228–236.
9. Goldberg IJ. Clinical review 124: Diabetic dyslipidemia: causes and consequences. *J Clin Endocrinol Metab* 2001;86:965–971.
10. Krauss RM. Lipids and lipoproteins in patients with type 2 diabetes. *Diabetes Care* 2004;27:1496–1504.
11. Guerin M, Le Goff W, Lassel TS, Van Tol A, Steiner G, Chapman MJ. Atherogenic role of elevated CE transfer from HDL to VLDL(1) and dense LDL in type 2 diabetes: impact of the degree of triglyceridemia. *Arterioscler Thromb Vasc Biol* 2001;21:282–288.
12. Sposito AC, Chapman MJ. Statin therapy in acute coronary syndromes: mechanistic insight into clinical benefit. *Arterioscler Thromb Vasc Biol* 2002;22:1524–1534.
13. Stary HC, Chandler AB, Dinsmore, Fuster V, Glagov S, Insull W Jr, Rosenfeld ME, Schwartz CJ, Wagner WD, Wissler RW. A definition of advanced types of atherosclerotic lesions and a histological classification of atherosclerosis. A report from the Committee on Vascular Lesions of the Council on Arteriosclerosis, American Heart Association. *Circulation* 1995;92:1355–1374.
14. Pasterkamp C, Falk E. Atherosclerotic plaque rupture: an overview. *J Clin Bas Cardiol* 2000;3:81–86.
15. Moreno PR, Fuster V. New aspects in the pathogenesis of diabetic atherothrombosis. *J Am Coll Cardiol* 2004;44:2293–2300.
16. Brown G. Maximizing coronary disease risk reduction using nicotinic acid combined with LDL-lowering therapy. *Eur Heart J* 2005;7(Suppl.):F34–F40.
17. Bruckert E, Baccara-Dinet M, McCoy F, Chapman J. High prevalence of low HDL-cholesterol in a pan-European survey of 8545 dyslipidaemic patients. *Curr Med Res Opin* 2005;21:1927–1934.
18. Ziegler M. New functions of a long-known molecule. Emerging roles of NAD in cellular signaling. *Eur J Biochem* 2000;267:1550–1564.
19. Altschul R, Hoffer A, Stephen JD. Influence of nicotinic acid on serum cholesterol in man. *Arch Biochem* 1955;54:558–559.
20. Tunaru S, Kero J, Schaub A, Wufka C, Blaukat A, Pfeffer K, Offermanns S. PUMA-G and HM74 are receptors for nicotinic acid and mediate its anti-lipolytic effect. *Nat Med* 2003;9:352–355.
21. Wise A, Foord SM, Fraser NJ, Barnes AA, Elshourbagy N, Eilert M, Ignar DM, Murdock PR, Steplewski K, Green A, Brown AJ, Dowell SJ, Szekeres PG, Hassall DG, Marshall FH, Wilson S, Pike NB. Molecular identification of high and low affinity receptors for nicotinic acid. *J Biol Chem* 2003;278:9869–9874.
22. Karpe F, Frayn KN. The nicotinic acid receptor—a new mechanism for an old drug. *Lancet* 2004;363:1892–1894.
23. Boden G, Chen X, Capulong E, Mozzoli M. Effects of free fatty acids on gluconeogenesis and autoregulation of glucose production in type 2 diabetes. *Diabetes* 2001;50:810–816.
24. Chapman MJ. Fibrates in 2003: therapeutic action in atherogenic dyslipidaemia and future perspectives. *Atherosclerosis* 2003;171:1–13.
25. McGovern ME. Niaspan®: creating a new concept for raising HDL-cholesterol. *Eur Heart J* 2005;7(Suppl. F):F41–F47.
26. Bays HE, McGovern ME. Once-daily niacin extended release/lovastatin combination tablet has more favorable effects on lipoprotein particle size and subclass distribution than atorvastatin and simvastatin. *Prev Cardiol* 2003;6:179–188.
27. Superko RH. Lipoprotein subclasses and atherosclerosis. *Front Biosci* 2001;6:D355–D365.
28. Morgan JM, Capuzzi DM, Baksh RI, Intenzo C, Carey CM, Reese D, Walker K. Effects of extended-release niacin on lipoprotein subclass distribution. *Am J Cardiol* 2003;91:1432–1436.
29. Ogilvie D, Hamlet N. Obesity: the elephant in the corner. *BMJ* 2005;331:1545–1548.
30. Colhoun HM, Betteridge DJ, Durrington PN, Hitman GA, Neil HA, Livingstone SJ, Thomason MJ, Mackness MI, Charlton-Menys V, Fuller JH. Primary prevention of cardiovascular disease with atorvastatin in type 2 diabetes in the Collaborative Atorvastatin Diabetes Study (CARDS): multicentre randomised placebo-controlled trial. *Lancet* 2004;364:685–696.
31. Kastelein JJP. The realities of dyslipidaemia: what do the studies tell us? *Eur Heart J* 2005;7(Suppl. F):F27–F33.
32. Chapman MJ. Are the effects of statins on HDL-cholesterol clinically relevant? *Eur Heart J* 2004;6(Suppl. C):C58–C63.
33. Gotto AM Jr, Brinton EA. Assessing low levels of high-density lipoprotein cholesterol as a risk factor in coronary heart disease: a working group report and update. *J Am Coll Cardiol* 2004;43: 717–724.
34. Chapman MJ, Assmann G, Fruchart JC, Shepherd J, Sirtori C. Raising high-density lipoprotein cholesterol with reduction of cardiovascular risk: the role of nicotinic acid—a position paper developed by the European Consensus Panel on HDL-C. *Curr Med Res Opin* 2004;20: 1253–1268.